



Automated Pallet Stackers

L-MATIC AC

Capacity 1.2 t – 1.6 t | Series 1170

PB

ION

Powerful pallet lifter

- Load capacity up to 1.6 t and lifting height up to 4.2 m
- Intelligent contour navigation requires no additional infrastructure
- Load pick-up at transfer stations which cannot be accessed from below
- Easy handling of closed bottom load carriers
- Comprehensive safety systems protect the vehicle and its surroundings

STANDARD AND OPTIONAL EQUIPMENT

Manufacturer's type designation/equipment		L-MATIC AC 1.2 t	L-MATIC AC 1.6 t
Off-Board Software	Interfaces to existing WMS and ERP systems	○	○
	Interfaces to infrastructure: doors, conveyors, etc.	○	○
	Linde WMS system	○	○
	Email updates on performance data	●	●
On-Board Software	Natural feature navigation	●	●
	Self-calibration algorithm	●	●
Safety	Front and rear safety scanners	●	●
	2D curtain laser in forward direction	●	●
	Side safety scanner for 360° safety	○	○
	Side safety bumper	●	●
	Linde BlueSpot - optical warning signal for pedestrians and other co-workers	●	●
	Additional emergency buttons	●	●
	Visual warning indicators - lights indicating vehicle status (warnings and alarms)	●	●
	Acoustic warning indicators	●	●
Load Handling	Mobile load detection	○	○
	3D camera load detection	○	○
	1D barcode reader	○	○
	2D barcode reader	○	○
	Side shift	○	○
Forks	ISO forks: 1200 × 80 × 40 mm	●	–
	ISO forks: 1200 × 100 × 45 mm	–	●
Environment	Data transmission via Wifi	●	●
	Touch screen with simple user interface	●	●
Energy	Lead-acid battery for manual charging	●	●
	Li-ION battery for automatic charging	○	○
	Truck prepared for automatic charging	○	○
	Lateral battery change	●	●
	Docking station for automatic charging	○	○

● Standard equipment ○ Optional equipment – Not available

MAST TABLES

STANDARD MAST (in mm)

Lift	h3: 1844		h3: 1924		h3: 4144		h3: 4224	
Height measurements	h1: 1515 h4: 2405	h2: 150 1739/1489*	h1: 1515 h4: 2485	h2: 150 1814/1564*	h1: 2665 h4: 4705	h2: 150 4039/3789*	h1: 2665 h4: 4785	h2: 150 4114/3864*
Manufacturer's type designation								
L-MATIC AC 1.2 t	—		○		—		○	
L-MATIC AC 1.6 t	○		—		○		—	

○ Optional equipment – Not available

h1: Mast height, lowered

h2: Free lift

h3: Lift

h4: Mast height, extended

*Pick height/Drop height

TECHNICAL DATA (according to VDI 2198)

			Linde MH	Linde MH	Linde MH	Linde MH	
			L-MATIC AC 1.2 t	L-MATIC AC 1.6 t	L-MATIC AC 1.2 t	L-MATIC AC 1.6 t	
Characteristics	1.1	Manufacturer (abbreviation)					
	1.2	Manufacturer's type designation					
	1.2a	Series					
	1.3	Drive					
	1.4	Operation					
	1.5	Rated capacity/rated load	Q (t)	1.2	1.6	1.2	1.6
	1.6	Load centre distance	c (mm)	600	600	600	600
	1.8	Load distance, centre of drive axle to fork	x (mm)	100 ¹⁾	105 ¹⁾	100 ¹⁾	105 ¹⁾
	1.9	Wheelbase	y (mm)	1270 ¹⁾	1635 ¹⁾	1270 ¹⁾	1635 ¹⁾
Weight	2.1	Service weight	kg	2060 ²⁾	2020 ²⁾	2275 ²⁾	2235 ²⁾
	2.2	Axle loading, laden front/rear	kg	613/2647 ²⁾	718/2902 ²⁾	613/2862 ²⁾	718/3117
	2.3	Axle loading, unladen front/rear	kg	1180/880 ²⁾	1310/710 ²⁾	1180/1095	1310/925
Tyres/chassis	3.1	Tyres: solid rubber, superelastic, pneumatic, polyurethane		Polyurethane	Polyurethane	Polyurethane	Polyurethane
	3.2	Tyre size, front	Ø × l (mm)	Ø 254 × 102	Ø 254 × 102	Ø 254 × 102	Ø 254 × 102
	3.3	Tyre size, rear	Ø × l (mm)	Ø 85 × 105	Ø 85 × 105	Ø 85 × 105	Ø 85 × 105
	3.5	Wheels, number front/rear (x = driven wheels)		1x/4	1x/4	1x/4	1x/4
	3.7	Tread, rear	b11 (mm)	483 ¹⁾	483 ¹⁾	483 ¹⁾	483 ¹⁾
Dimensions	4.2	Mast height, lowered	h1 (mm)	1515	1515	2665	2665
	4.3	Free lift	h2 (mm)	150	150	150	150
	4.4	Lift	h3 (mm)	1924	1844	4224	4144
	4.5	Mast height, extended/with load backrest	h4 (mm)	2485/3576	2405/3501	4785/6433	4705/6358
	4.6	Initial lift	h5 (mm)	0	0	0	0
	4.9	Height drawbar in driving position min./max.	h14 (mm)	1140/1350	1140/1350	1140/1350	1140/1350
	4.15	Height, lowered	h13 (mm)	40	45	40	45
	4.19	Overall length	l1 (mm)	2900 ¹⁾	3270 ¹⁾	2900 ¹⁾	3270 ¹⁾
	4.20	Length to fork face	l2 (mm)	1700	2065	2065	2065
	4.21	Overall width	b1/b2 (mm)	790/890 ¹⁾	790/890 ¹⁾	793/890 ¹⁾	794/890 ¹⁾
	4.22	Fork dimensions DIN ISO 2331	s/e/l (mm)	40/80/1200	45/100/1200	40/80/1200	45/100/1200
	4.23	Fork carriage to ISO 2328, class/type A, B		2B	2B	2B	2B
	4.24	Fork carriage width	b3 (mm)	876	876	876	876
	4.25	Fork spread	b5 (mm)	314/682	314/682	314/682	314/682
	4.32	Ground clearance, centre of wheelbase	m2 (mm)	40	40	40	40
	4.34.1	Aisle width for pallets 1050 × 1250 across forks, auto mode	Ast (mm)	3370	3730	3430	3800
	4.34.2	Aisle width for pallets 850 × 1250 in length, auto mode	Ast (mm)	3340	3710	3340	3710
4.35	Turning radius auto mode	Wa (mm)	1668	2033	1668	2033	
Performance	5.1	Travel speed load direction, laden/unladen	m/s	1.7/1.7	1.7/1.7	1.7/1.7	1.7/1.7
	5.1a	Travel speed drive direction, laden/unladen	m/s	0.8/0.8	0.8/0.8	0.8/0.8	0.8/0.8
	5.2	Lifting speed, laden/unladen	m/s	0.15/0.3	0.15/0.3	0.15/0.3	0.15/0.3
	5.3	Lowering speed, laden/unladen	m/s	0.45/0.35	0.45/0.35	0.45/0.35	0.45/0.35
	5.8	Max. gradeability, laden/unladen	%	3/3	3/3	3/3	3/3
	5.10	Service brake		Electro-magnetic	Electro-magnetic	Electro-magnetic	Electro-magnetic
Electric-engine	6.1	Drive motor rating S2 60 min	kW	3	3	3	3
	6.2	Lift motor rating at S3 15%	kW	3	3	3	3
	6.3	Battery according to DIN 43531/35/36 A, B, C, no		no	no	no	no
	6.4	Battery voltage/rated capacity (5h)	(V)/(Ah)	24/375	24/500	24/375	24/500
	6.5	Battery weight	kg	295	365	295	365
	6.6	Energy consumption in relation to VDI cycle (X cycles/1h)	kWh/h	1.45	1.45	1.45	1.45
Drive/lift mechanism	8.1	Type of drive unit		LAC	LAC	LAC	LAC
	10.7	Sound pressure level LpAZ (at the operator's seat)	dB (A)	<70	<70	<70	<70

1) ±5 mm 2) ±10%

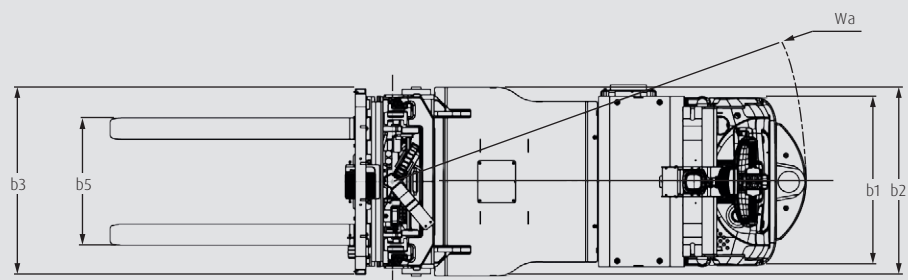
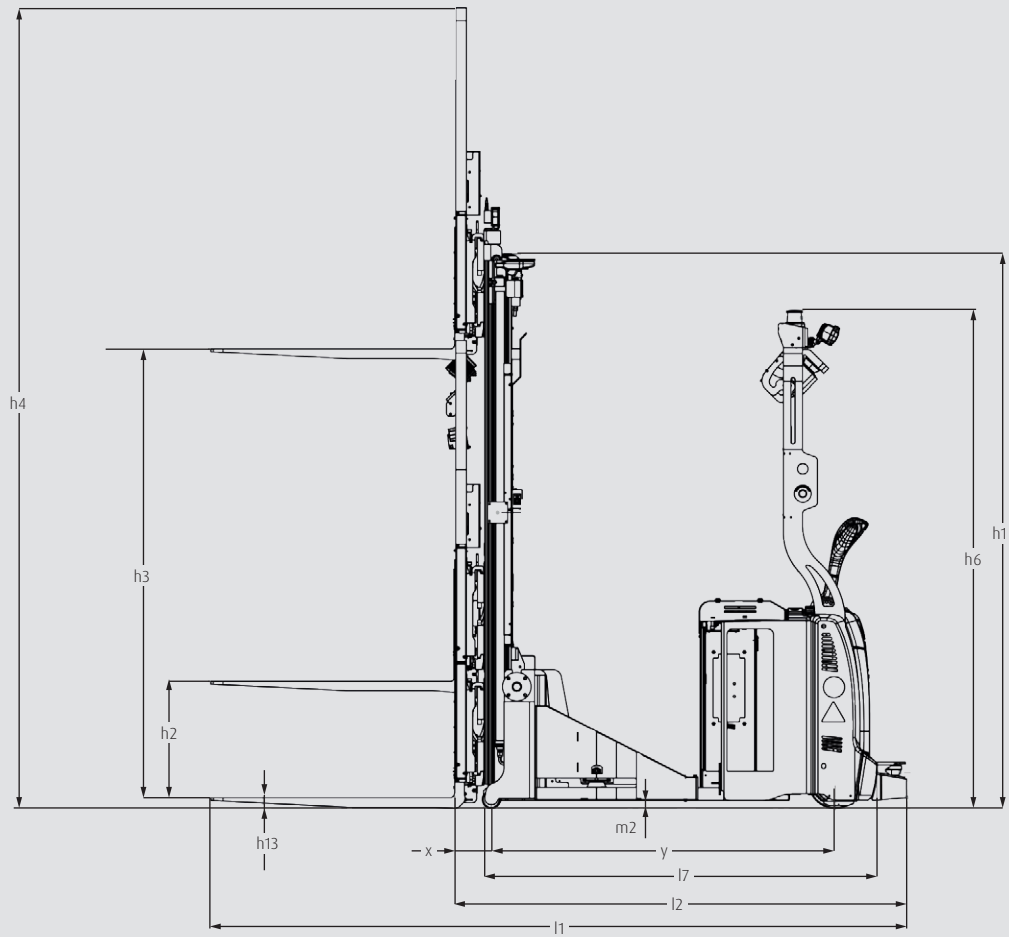

CHARACTERISTICS



2D curtain laser for obstacle detection

Safety

- Safety system automatically recognises people and obstacles
- Truck stops immediately if there are obstacles in the danger zone
- Comprehensive safety thanks to warning sounds, flashing lights and Linde BlueSpot
- Numerous emergency stop buttons for rapid hazard prevention
- Safe co-operation with people, other vehicles and infrastructure



Manual operation option

Handling

- Interaction with other systems such as industrial doors or roller conveyors
- Route guidance and order assignment via master control
- Optional interface to merchandise management or ERP system
- Contour navigation enables quick adaptation to new working environments
- Switch to manual mode available



Excellent operational availability

Service

- High reliability thanks to proven Linde technology
- Robust design reduces maintenance costs
- Fast, easy access to major components maximizes up-time
- Control unit networking means data can be accessed via a laptop
- Linde service network and central hotline ensures high product availability



Process-oriented as standard

Sales and implementation

- Project-specific automated solutions including dynamic simulation and proof of concept on site
- Manual handling processes and the degree of automation can be optimized to suit customer needs
- Single point of contact at Linde MH, from initial contact to project implementation and commissioning
- Intelligent and scalable software solutions give the customer optimum control over all processes
- Project management and commissioning in accordance with Linde MH standards with uniform tools and templates used throughout the sales network

Subject to modification in the interest of progress. Illustrations and technical details could include options and are not binding for actual constructions. All dimensions subject to usual tolerances.



ncnielsen

Nørregade 66, DK-7860 Balling | Tlf.: +45 99 83 83 83
nc-nielsen.dk | info@nc-nielsen.dk